



## VID28 Series Stepper Motor

### Description

#### VID28-XX series

Is a precise stepping motor of patent design, with a reduction ratio of 1/180. It's an innovation products based on our company product VID29-xx, and it can drive two point independently, this motor could help dashboard designer save space in dial surface design and benefit for new concept design. It's mainly used in dashboard instrumentation or other digital indicator equipments, to transfer digital signals directly and accurately to analog display output.

#### VID28-XX series

Is driven by dual signals of 2 sequent logic pulse. It can be driven in 3.5V ~ 10V providing shaft stepping angle resolution 1/12°. The pointer can move with a speed more than 500Hz.

#### VID28-XX series

A new and modern design increase high efficiency, high position accuracy and extremely robust gear system. The special gear shape is helpful to decrease friction and noise. It chooses appropriate material for each component to increase durability and safety of the motor. All these futures enhance VID motor's stability and long life time.

#### The main features are:

- High speed rotation: 500Hz.
- High  $\mu$ -step resolution: 1/12°.
- Wide working voltage: 3.5~10V.
- Wide working temperature: -40~105°C.
- Low current consumption: less than 20mA, 5V, 2X100mW.
- Extremely robust construction: 64mm × 35mm × 9.2mm.
- Long lifetime: in 200Hz, constant working up to 5000Hrs.
- Directly driven by a  $\mu$ -controller.

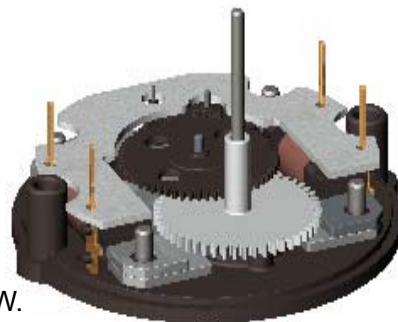

#### Typical application:

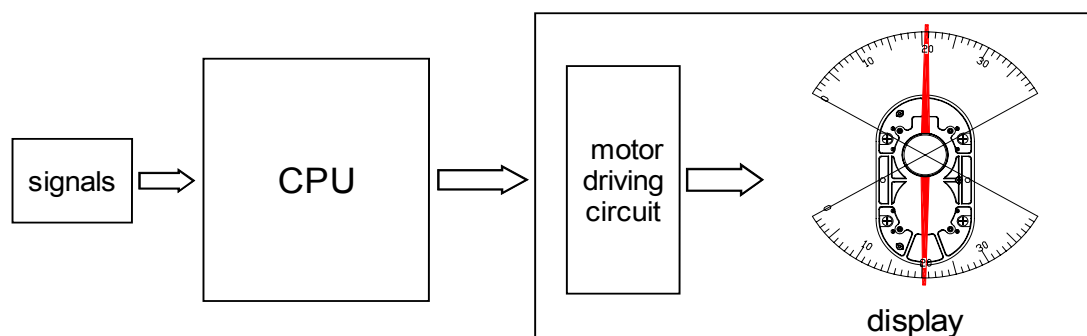

perfect combination of digital accuracy and analog facility

## Step Definition and Rotor Movement

VID28-XX series is driven by dual signals of 2 sequent logic pulse signals and its inner shaft has 4 gears its outer shaft has 5 gears idesign to construct high efficiency, and the outer shaft is Its work diagram is as following:

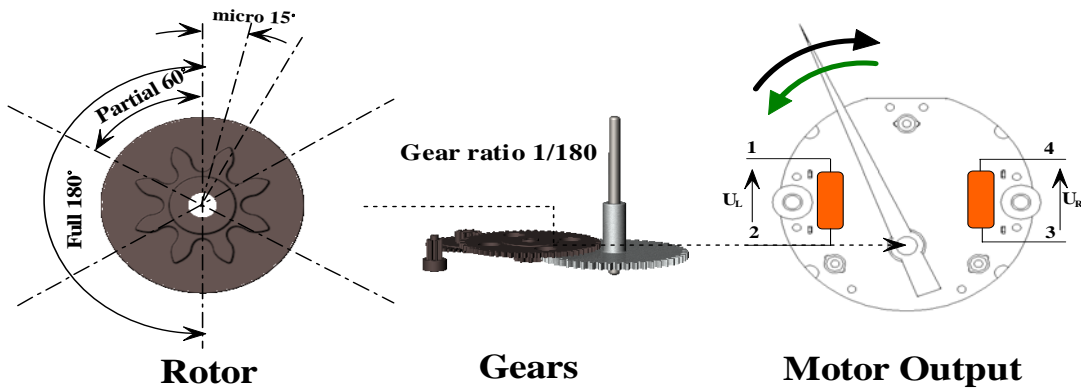
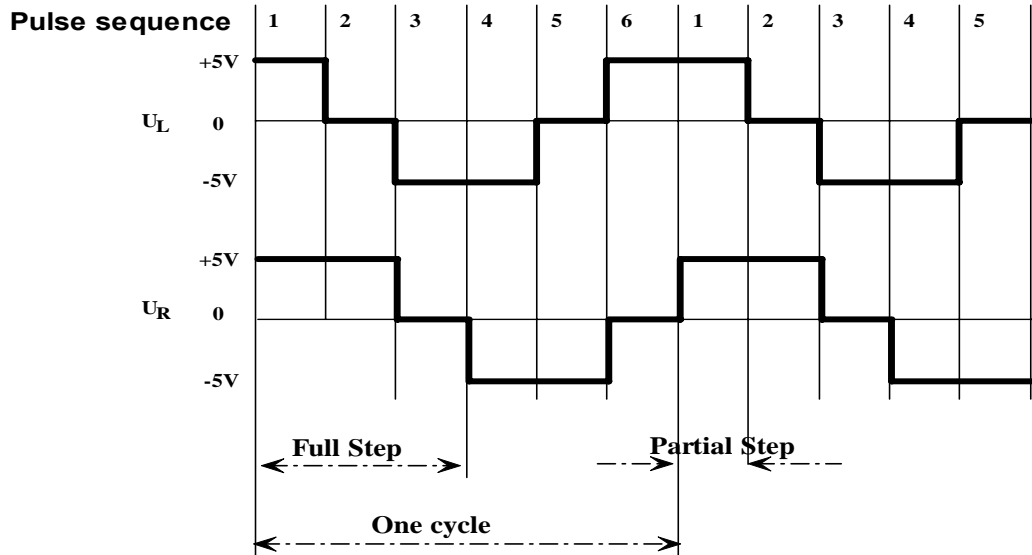

In order to make the motor run more stably and reduce its noise, micro stepping technology is recommended. The micro pulse sequence which is more precise and near to sine wave, which could drive motor with  $1/12^\circ$  micro step of the pointer. The diagram is as following:

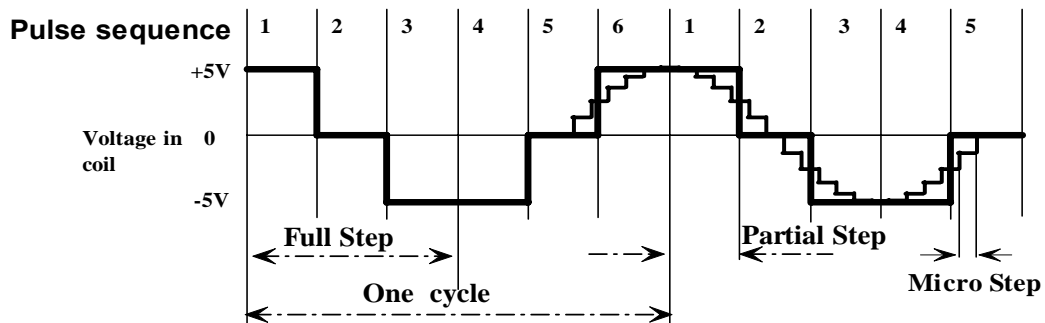

For more details about the micro stepping driving signals, please see specified files.



A Company of Wellgain Group

## Absolute Maximum Ratings

Driving voltage (Ub).....10V  
 EMI tolerance (1 kHz;AM 80%; 100 kHz - 2 GHz) .....80 V/m  
 Solder temperature (10 sec).....260°C

## Electrical and Mechanical Characteristics

- The electrical and mechanical characteristics of inner shaft refer to VID29 spec.
  - The following list is only for out shaft
- T<sub>amb</sub>=25°C, In micro step mode @ Max. voltage 4.2V, unless other specified.

Parameter	Symbol	Test Conditions	Min.	Typ.	Max	Units
<b>Electrical Characteristics</b>						
Operating Temperature	T <sub>a</sub>		-40		105	°C
Coil Resistance	R <sub>b</sub>			280		Ω
Operating Current	I <sub>m</sub>	f <sub>a</sub> =200Hz			20	mA
Start-Stop Frequency	f <sub>ss</sub>	J <sub>L</sub> =0.2x10 <sup>-6</sup> kgm <sup>2</sup>	125			Hz
Maximum Driving Frequency	f <sub>mm</sub>	J <sub>L</sub> =0.2x10 <sup>-6</sup> kgm <sup>2</sup>	400			Hz
<b>Mechanical Characteristics</b>						
Dynamic Torque	M200	f <sub>a</sub> =200Hz		1.1		mNm
	M400	f <sub>a</sub> =400Hz		0.7		mNm
Static Torque	M <sub>s</sub>	U <sub>b</sub> =5V	3.5	4.0		mNm
Equivalent Motor Inertia @ Output	J <sub>m</sub>			5.064 E-7		Kgm <sup>2</sup>
Gear ratio				180:1		
Step size in full step mode				1		Degree
Step size in partial step mode				1/3		Degree
Step size in micro step mode				1/12		Degree
Backlash				0.7		Degree
<b>Noise</b>						
Noise Level	SPL	@200°/sec		46		dBA
<b>Others</b>						
Angle of	Inner Shaft	f <sub>i</sub>	Motors with		315	Degree



# Stepper Motor Specification

Type:VID28-XX  
Revision:1

A Company of Wellgain Group

Rotation	OuterShaft		internal Stop			280	Degree
Force allowed on the pointer shaft:							
Axial force (push)		Fa				60	N
Axial force (pull)		Fa				60	N
Perpendicular force		Fq				6	N
Imposed acceleration		$\alpha_p$				1000	rad/s <sup>2</sup>
Number of allowed pointer insertion						1	Times

Note:  $f_a$  – full-step frequency  $J_L$  – Load inertia

## Typical torque and noise

**Torque** in micro step driving mode, @ Max voltage  $U_b = 4.2V$

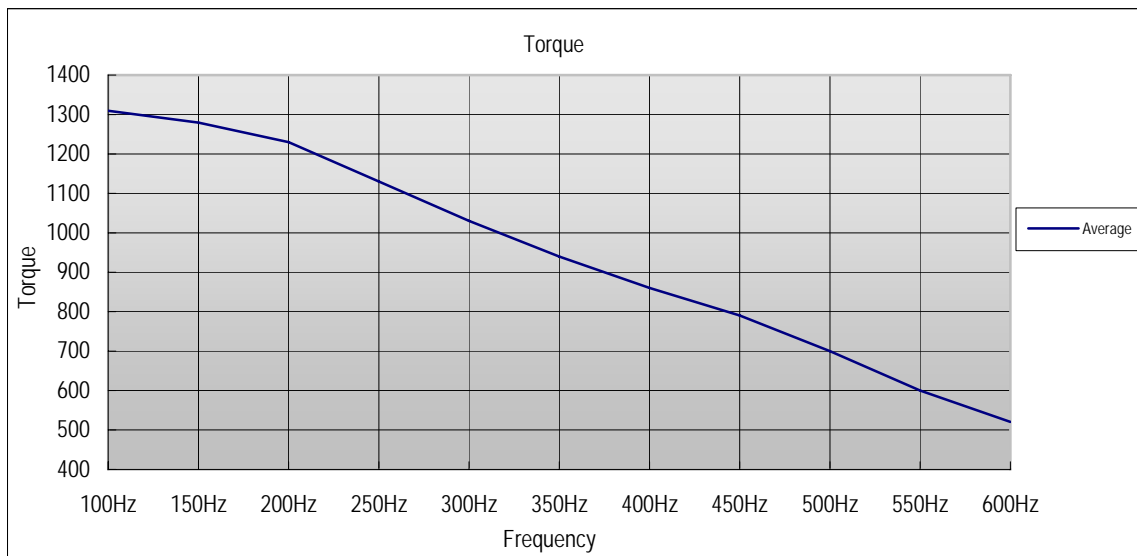

**Noise** in micro step driving mode, @ Max voltage  $U_b = 4.2V$

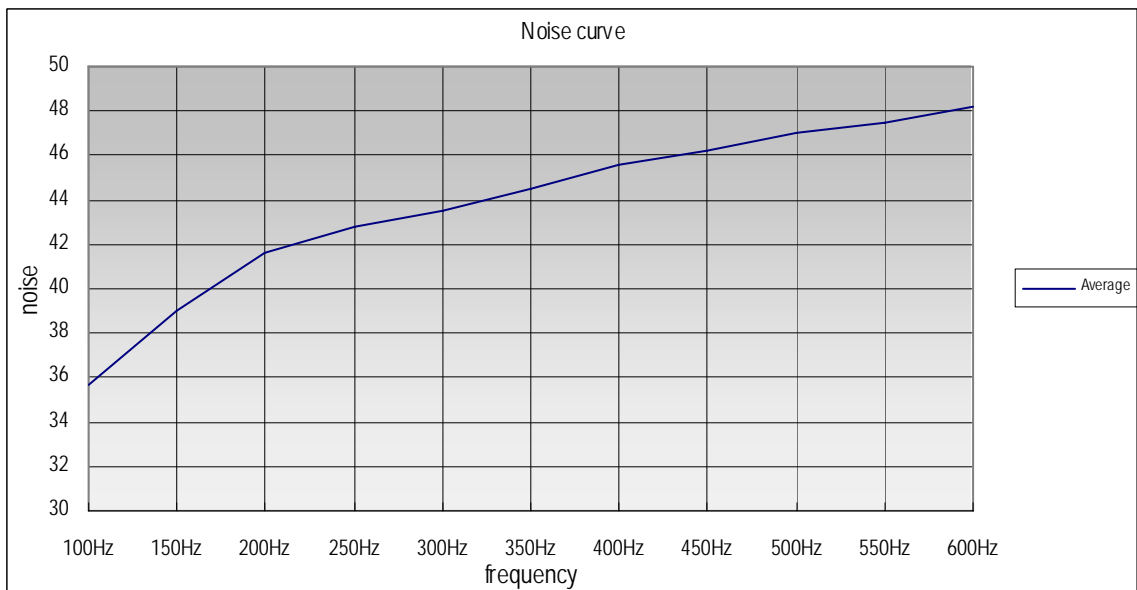



## Pin Connection

### VID28-XX Pin Connection

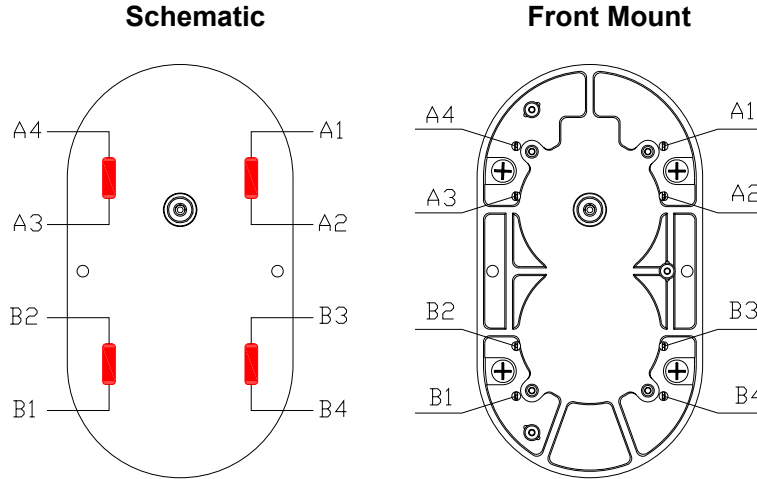

## Suggested Installation

The VID29 can be easily installed. The four contact pins can be soldered on PCB circuits. If the application is subject in very strong vibrations, screws might be necessary.

### Installation Diagram

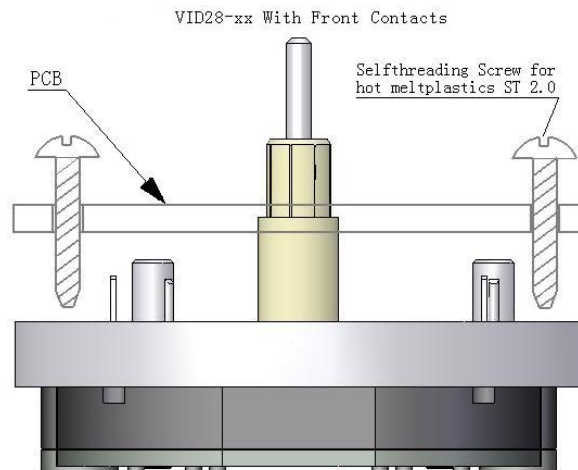

## Application hint

The parameter of the pointer:

	Min	Typical	Suggested MaxValue(*)
Size:		50mm	80mm
Weight:		2.5g	10g
Inertia moment:		$2 \times 10^{-7} \text{ kgm}^2$	$20 \times 10^{-7} \text{ kgm}^2$
Unbalance:		0.01mNm	0.025mNm



## Driving Pulse and Control Circuit

### Partial-Step Driving Mode

In partial-step driving mode, the motor can be directly driven by a standard logic voltage level with less than 20mA current consumption. The bit-time sequence determines the turning direction of the motor. The time sequence diagram is as following:

#### Driving Pulse in Partial Mode

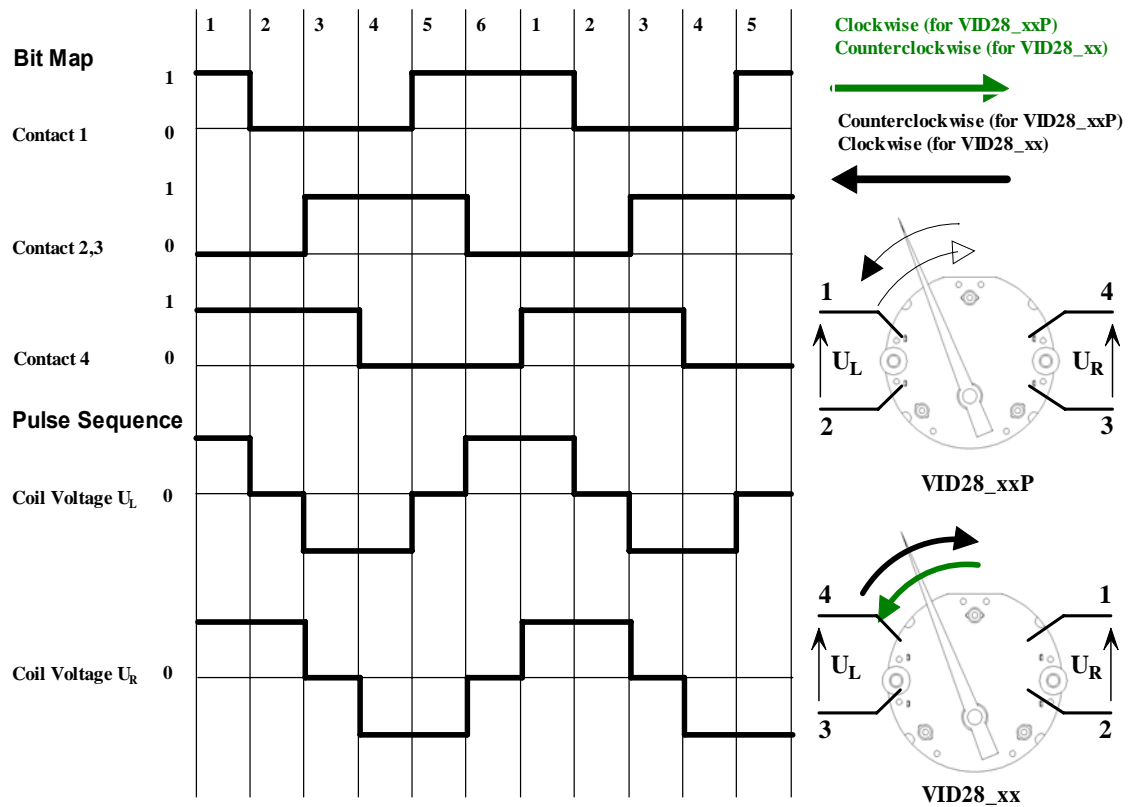

#### Driving Diagram in Partial Mode

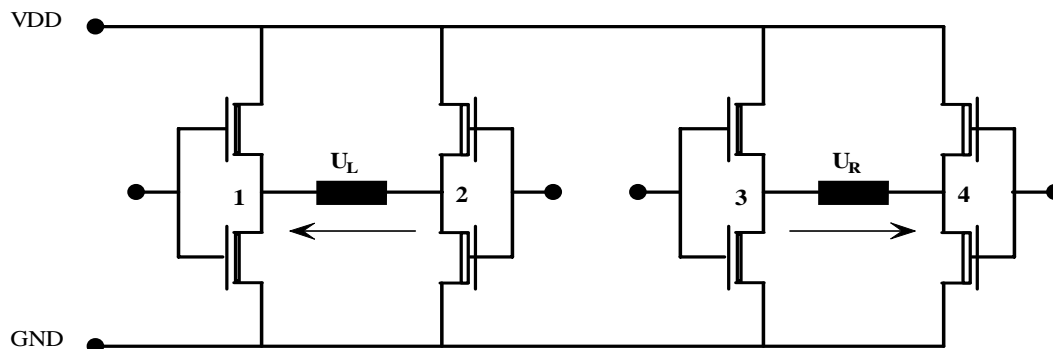



## μ-Step Driving Mode

In μ-step driving mode, the motor can be driven by a current-level sequence. A μ-step is a 0.083° of pointer. The driving pulses consist of many different current level pulse sequences. The μ-step provides the pointer shaft continuous, smooth movement.

### Example of driving Pulses in μ-step Mode

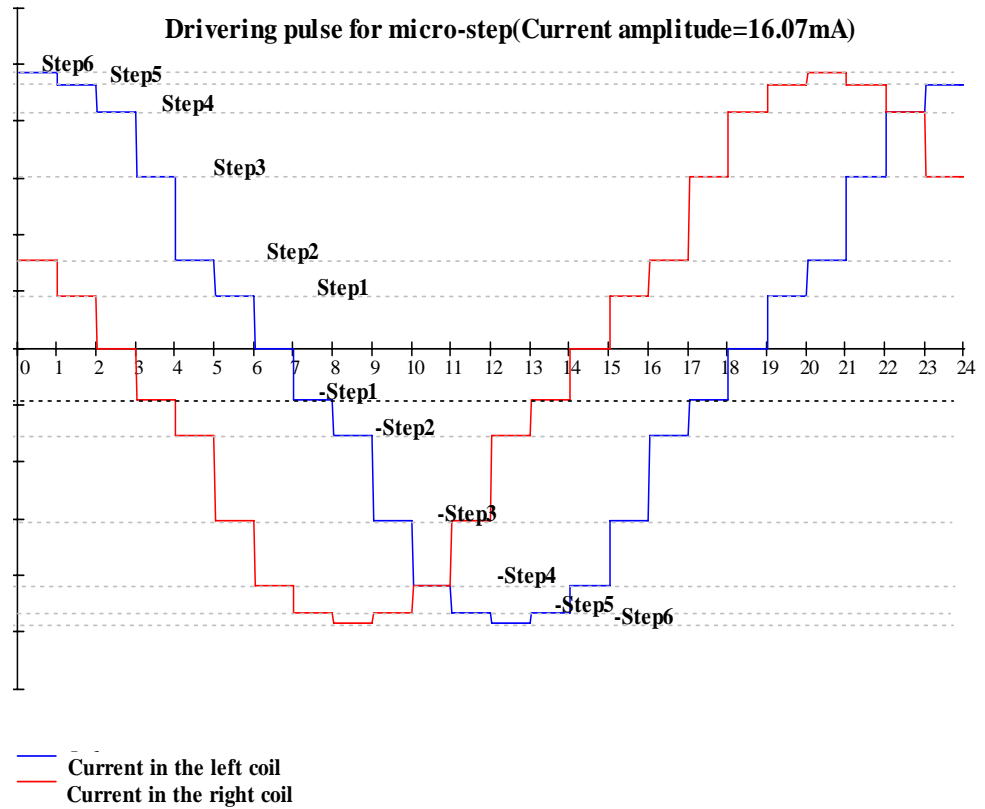

In general the peak amplitude should be between 12.9mA and 16.07mA.

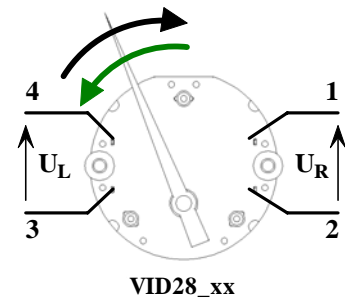
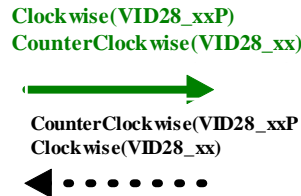
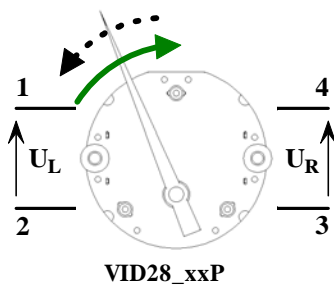



## **Suggested Reseting Process**

In most of the VID28-XX applications, the angular range of the instrument dial is less than 260°. This allows use of a mechanical stop to define the zero position. Generally the pointer will be reset to the zero position at each power-up of the instrument.

During the power-up of instrument, to bring the pointer at his initial stop position without creating any visible and audible jitter of the pointer, we suggest frequency acceleration process to speed up VID29 step motor till a high speed. Below is an example:

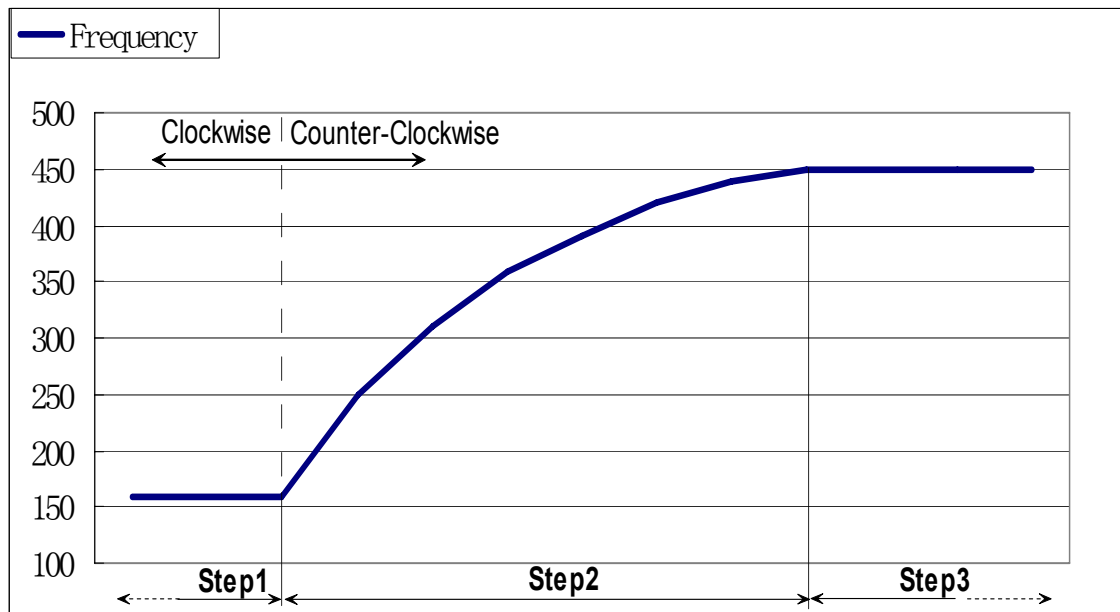

•





## Reliability Test (stepper motor)

### Temperature Cycle Test

- Low Temperature:-40°C±2°C
  - High Temperature:+105°C±2°C
  - Dwell time:1 Hrs/each
  - Transfer Time:1.5 hrs
  - Cycle:50 Cycles
  - Motor Status : running
  - The test was carried out according to IEC68-2-14 and PF-9688(DaimlerChrysler)
- Temperature change like the following curve

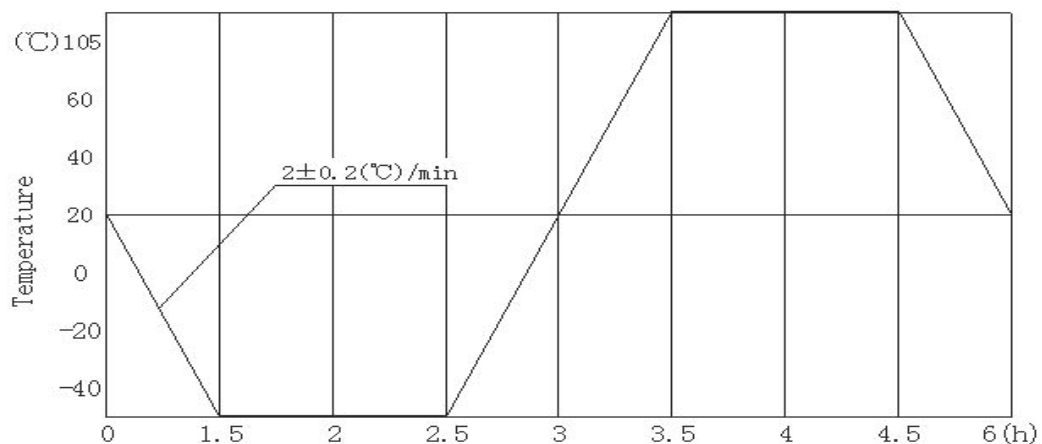

### Thermal Shock Test

- Low Temperature:-40°C±2°C
- High Temperature:+85°C±2°C
- Dwell time:30 Minutes/each
- Transfer Time:within 30 seconds
- Cycle:100 Cycles
- Motor Status: non-running
- The test was carried out according to IEC68-2-14 and PF-9688(DaimlerChrysler)

### Humidity Test

- Temperature:+50°C±2°C
- Humidity:94±2%RH
- Duration:144 Hrs
- Motor Status: non-running
- The test was carried out according to IEC68-2-3 and PF-9688(DaimlerChrysler)



## Stepper Motor Specification

Type:VID28-XX  
Revision:1

A Company of Wellgain Group

### High Temperature Test

- Temperature:+105°C±2°C
- Duration:168 Hrs
- Motor Status : running
- The test was carried out according to IEC68-2-2 and PF-9688(DaimlerChrysler)

### Low Temperature Test

- Temperature:-40°C±2°C
- Duration:48 Hrs
- Motor Status : running
- The test was carried out according to IEC68-2-1 and PF-9688(DaimlerChrysler)

### Mechanical Vibration Test

- Pulse shape:sine pulse form
  - Range of frequency:5Hz~200Hz(logarithm sweep)
  - Sweep cycle: 315 sec.
  - Direction:X,Y axis
  - Duration:8 hrs /each Direction
  - Acceleration : 6 g
  - Motor Status : running
  - The test was carried out according to IEC68-2-6
- Frequency change with time :

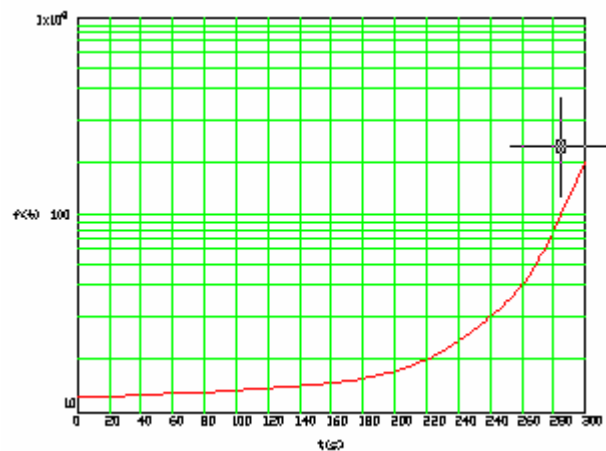

### Mechanical Shock Test

- Height: 1 m
- Direction:X/Y/Z
- Motor Status : non-running
- The test was carried out according to IEC68-2-62 and ISO 1413



A Company of Wellgain Group

## Packing Sketch Map

<p>Tray for 50 stepper motors VID28</p> <p>Material : PP</p> <p>Weight :   Tray                   1x210g=210g              Motors               100x9g=900g              Total                   1110g</p>	
<p>Stack for 500 motors VID28:</p> <p>Material : 11Trays (including Cover) strappedtogether with plastic band</p> <p>Weight : Trays               10x1110g=11100g           Cover tray       1x210g=210g           Plastic strap   2x15g=30g           Total             11340g</p>	
<p>Master-carton for 500 motors VID28:</p> <p>Material : cardboard       710g/m</p> <p>Weight : Master-carton   1x900g=900g           PE bag             2x50g=100g           Production       1x11340g=11340g           PE                 4x60g=240g           Total             12580g</p>	
<p>A cardboard of motors       12580g</p> <p>Plastic strap               2x15g=30g</p> <p>Total                       12610g</p>	